

HYPOGEN 2.0 Auto

Producing a Hypochlorous solution on-site has never been easier



The HYPOGEN model 2.0 Auto

The ChlorKing® HYPOGEN 2.0 Auto is a stand-alone, on-site generator optimized to produce hypochlorous acid with an adjustable pH. Using ChlorKing technology the system converts salt, water and electricity into an effective and powerful solution that can substitute for a number of conventional chemicals used on a daily basis. This translates to a strong supply chain and savings over time. Keeping your business operating smoothly is easy with a HYPOGEN auto.

Uses

- Bacteria inactivation
- Virus inactivation
- Cleaning food surface preparation areas
- Tile floor cleaning
- Any situation where sodium hypochlorite or calcium hypochlorite have traditionally been used.

Skid dimensions and weight	
Depth x Width x Height	19" x 36" x 60"
Weight	120 lbs.

Shipping dimensions and weight (Crate)	
Depth x Width x Height (crate)	24" x 40" x 70"
Weight	316 lbs.
Pallet with salt & vinegar feeder	40" x 48" x 30"
Pallet weight	82 lbs.
Harmonized tariff code	8421.21.00

Electrical requirements	
Max AC primary amps	3.5amps @ 110v
Voltage / Hz	110-240v 50/60Hz
Phase	Single
Breaker required	15 amp

Generator performance	500ppm FAC	1,000ppm FAC
Water flow	0.24 gpm	0.1gpm
Water pressure (min)	25psi (2 Bar)	
Water pressure (max)	50psi (4 Bar)	
Water softener required	No	No
Hypochlorous acid produced	346 gallons / day	144 gallons / day
pH of solution (6.0 default)	5.5 (6.0) / 6.5 / 7.0 selectable	
FAC of generated solution	>500ppm	>1,000ppm
Estimated salt usage (lbs. used / gal. produced)	7.9 lbs. / 346 gal.	3.3 lbs. / 144 gal.
At ph 6.0 Estimated vinegar usage (Diluted gal. used / gal. produced)	0.9 gal. / 346 gal.	0.7 gal. / 144 gal.

Specifications	
Power supply	50amp 24v DC switch mode
Electrode stack (cell)	10,000 - 15,000 hour reverse polarity
Operating temperature (Air)	45°F - 115°F (7°C - 46°C)
Operating temperature (Water)	50°F - 80°F (10°C - 26°C)

Dimensions

SKID MOUNTED HYPOGEN

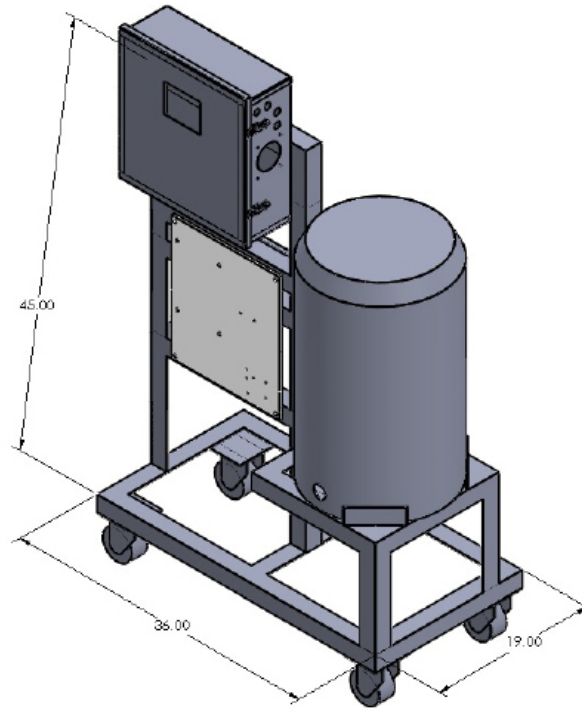

ACID / VINEGAR FEEDER

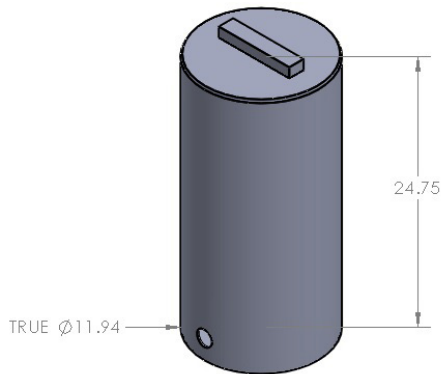

SALT FEEDER

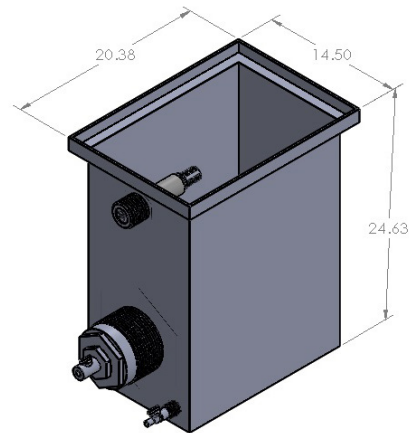

ChlorKing pioneered on-site chlorine generating technology in the 1970's. Realizing the potential for swimming pools and commercial applications, the company began generating "ultimate water" with simple, yet highly advanced technology. Today, ChlorKing® leads the way in commercial saline chlorination and is consistently seeking new frontiers in sanitizing solutions including ultraviolet light technology and their NEX-GEN® pH onsite chlorine generators. These environmentally friendly solutions are changing the way we treat H₂O.



Safer water through smarter technology.

Salt Chlorination Systems • Ultraviolet Light Systems • Mixed Oxidant Systems

ChlorKing Inc. 2935 Northeast Parkway Atlanta, GA 30360 sales@chlorking.com 800.536.8180 chlorking.com